

*Owner's Manual*

**DB-IH**

*Bench Scale*

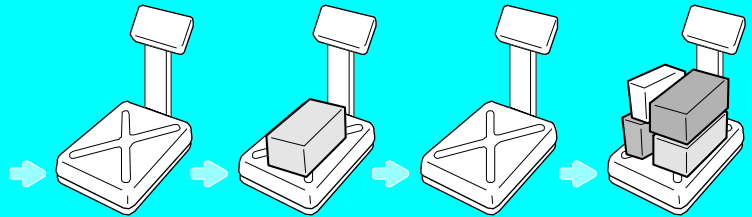

## CONTENTS

<b>PRECAUTIONS</b> .....	<b>4</b>
<b>PREFACE</b> .....	<b>6</b>
<b>NAMES AND FUNCTIONS</b> .....	<b>6</b>
<b>INSTALLATIONS</b> .....	<b>7</b>
<b>OPERATIONS</b> .....	<b>8</b>
1. General Weighing .....	<b>8</b>
2. Weighing with Tare .....	<b>9</b>
<b>ERROR MESSAGES</b> .....	<b>9</b>
<b>SPECIFICATIONS</b> .....	<b>10</b>
<b>SPECIFICATIONS FOR CE MARKED PRODUCT</b> .....	<b>10</b>

## PRECAUTIONS

Make sure that you plug your scale into the proper power outlet. Plug into a power outlet 30 minutes before operations.

Place the scale on a flat and stable surface.

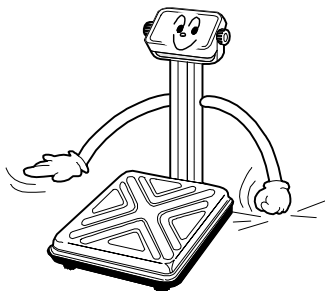

Do not put the scale on a sudden temperature changes.

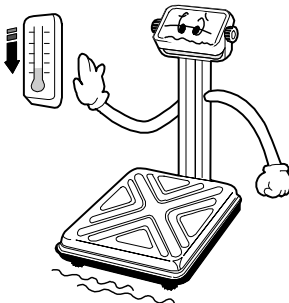

Do not put the scale on a sudden impact to the platter.

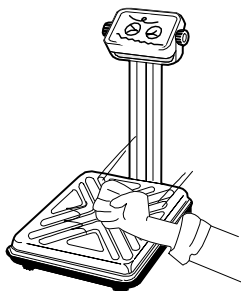

This scale must be installed in a dry and liquid free environment.

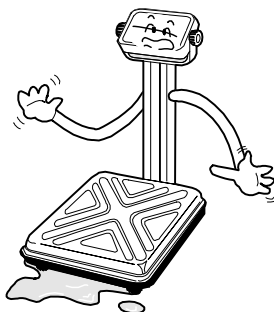

If the scale is not properly level, please adjust the 4 legs at the bottom of the scale (turn legs clockwise or counterclockwise) so as to center the bubble of the leveling gauge inside the indicated circle (See Fig.)

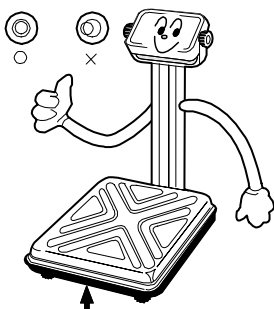

Leveling gauge

Keep away from the place which occurs the strong EMI noises.

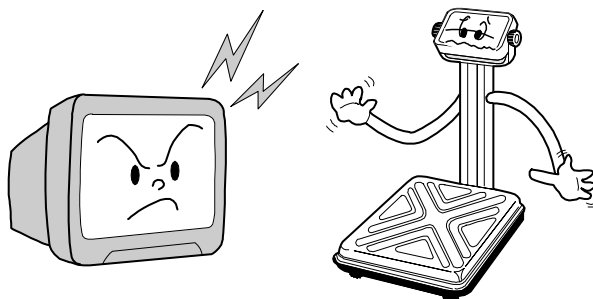

## PREFACE

Thank you for purchasing our CAS DB-1H series scale.

These series have been designed with CAS reliability, under rigid quality control and with outstanding performance. Your specialty departments can enjoy these high quality reliable CAS products.

We believe that your needs will be satisfied and you will have reliability.

This manual will help you with proper operation and are of the DB-1H series.

Please keep this handy for future reference.

## NAMES AND FUNCTIONS



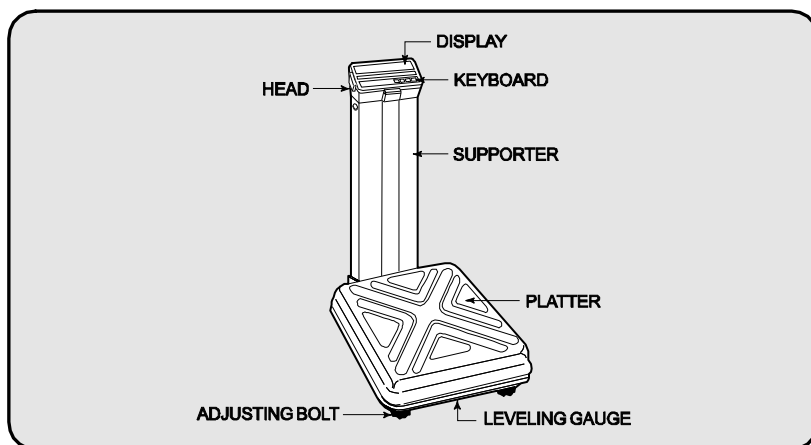

### OVERALL VIEW

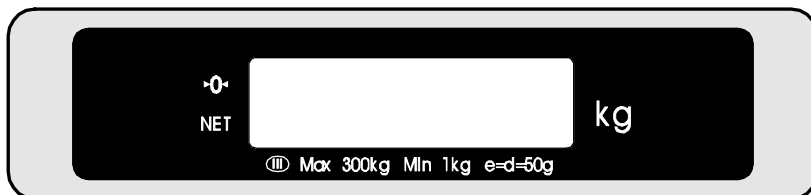

### DISPLAY



## KEYBOARD

KEYS	FUNCTIONS
	Turn the displays on or off.
	Used to correct the zero point
	Used to enter a tare weight. Used to clear a tare weight.
	No function key.

## INSTALLATIONS

1. Insert the power line into the support.  
Fasten with bolts and nuts as fig 1.

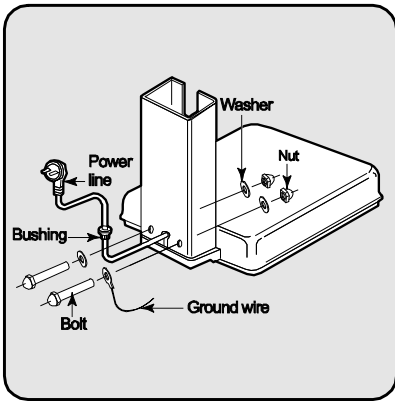

fig. 1

2. Fix a ground wire with bolt then  
arrange the power line and loadcell  
line as fig 2.

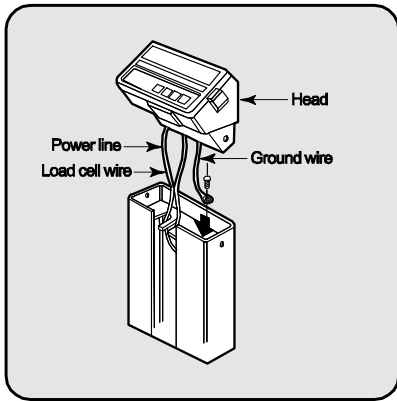

fig. 2

3. Insert the support cover into the support as fig 3.

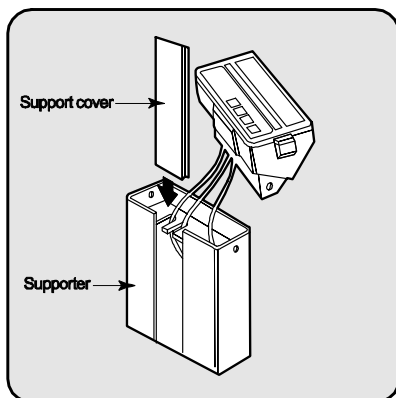

fig. 3

4. Attach the head to the support.  
Insert and fasten stop bolt as fig 4.

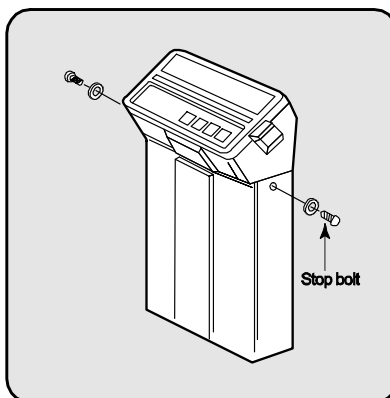

fig. 4

## OPERATIONS

### 1. General Weighing

- When you turn on the power switch, the scale will count “00000” to “99999”. Then the scale will read “0.00” in the weight display. This is called the ZERO state. If the scale is not ZERO state though there is nothing on the platter, press the **▶0◀** key.
- The display indicates if the scale is at zero or if there is a tare entered into the scale by way of a **▶0◀** and NET lamps.



Place the commodity on the platter.



Remove the commodity from the platter.

# 1. General Weighing

- Tare is the weight of container being used for a commodity.
- The **T** key subtracts the weight of the container.

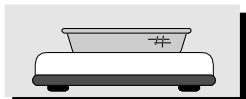

□ Place the container on the platter.

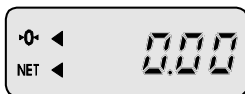

□ Press the **T** key.

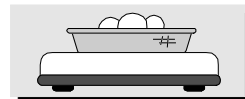

□ Place the commodity in the container.

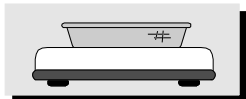

□ Remove the commodity from the platter.

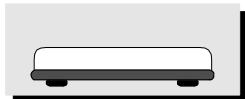
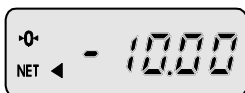

□ Remove the container from the platter, then you will see tare weight with “-”.



□ Press “**T**” key.

# ERROR MESSAGES

To help the customer’s understanding, this scale warns the user with proper error message. Please refer to the table below.

ERROR	REASON	SOLUTIONS
Err 1	An error of the initial ZERO range	1. Make sure that the platter is empty 2. Make sure that there is a platter on the scale
Err 2	Failure of returning the normal mode	Call your CAS dealer
Err 10	Failure of the analog module	Call your CAS dealer
Err 11	Failure of the digital module	Call your CAS dealer
Err 12	Condition codes are broken	Call your CAS dealer

## SPECIFICATIONS

MODEL	DB-1H		
CAPACITY	30kg x 5/10g	60kg x 10/20g	150kg x 20/50g
DISPLAY : WEIGHT	Vacuum Fluorescent Display5 DIGIT		
DI SPLAY DESIGNATORS	•0•		and NET
MAXIMUM TARE	-30.00kg	-60.00kg	-99.95kg
POWER SOURCE	110/220V, 50/60Hz		
POWER CONSUMPTION	APPROX. 10W		
PLATTER SIZE (mm)	530(W) x 406(D)		
PRODUCT SIZE (mm)	420(W) x 635(D) x 765(H)		

□ Notice: Specifications are subject to change for improvement without notice.

# SPECIFICATIONS FOR CE MARKED PRODUCT

## 1. Symbol Description

SYMBOL	PUBLICATION	DESCRIPTION
~	IEC 417. NO. 5032	ALTERNATING CURRENT
	IEC 417. NO. 5019	PROTECTIVE CONDUCTOR TERMINAL

## 2. Electrical conditions for LVD (Low Voltage Directive) testing.

Power source: AC 220V ~ 240V 50Hz, 250mA, 10W

Insulation class: {

## 3. Environment Conditions for non-automatic weighing instrument.

This product is intended to be “indoor use”.

Altitude: less 2000m

Temperature range: -10°C ~ +40°C

Maximum RH 80% (31°C), decreasing linearly to 50% RH at 40°C

Supply voltage fluctuations: 10% of the normal voltage.

Installation category: |{

Pollution degree: |{

## 4. Capacity: 30kg x 10g, 60kg x 20g, 150kg x 50g

## 5. How to connect the power supply

The power switch is located on the left side of the scale.

Make sure that the power switch is “OFF”.

Plug the scale into AC socket and make sure that the socket's power is within the scale's operating range. Turn the power switch “ON”.

## 6. The socket-outlet shall be installed near the equipment and shall be easily accessible.

## 7. Do not pour water directly on the scale. Use the plastic cleaner to clean your scale.

## 8. Changes or modifications not expressly approved by manufacturer for compliance could void the user's authority to operate the equipment.

**; Above statements can be applied to CE marked product.**



# MEMO

# MEMO

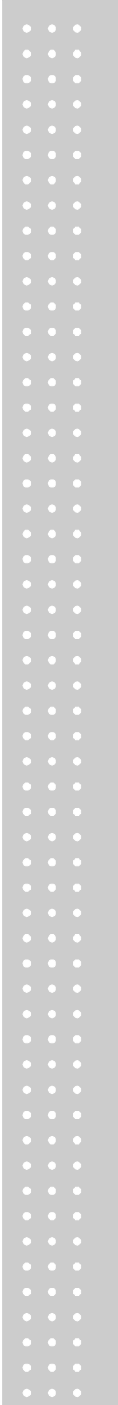

# MEMO

